

Top View

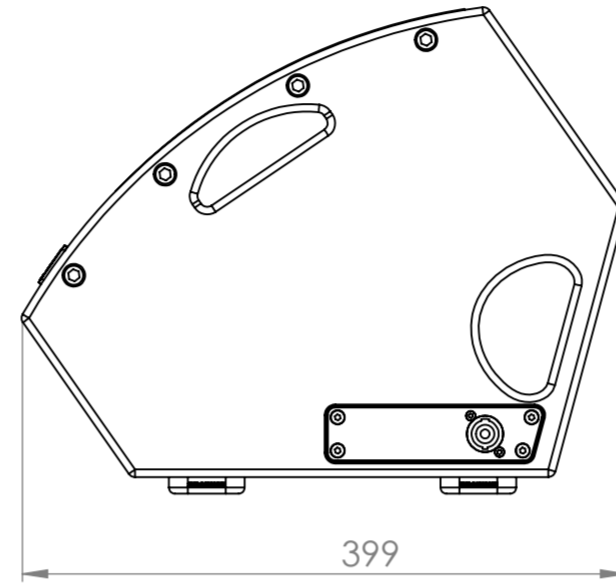

Side View

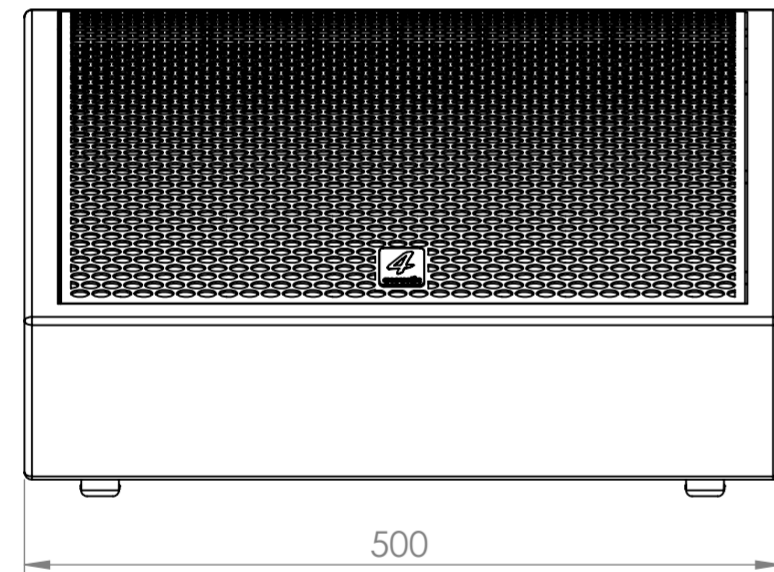

Front View

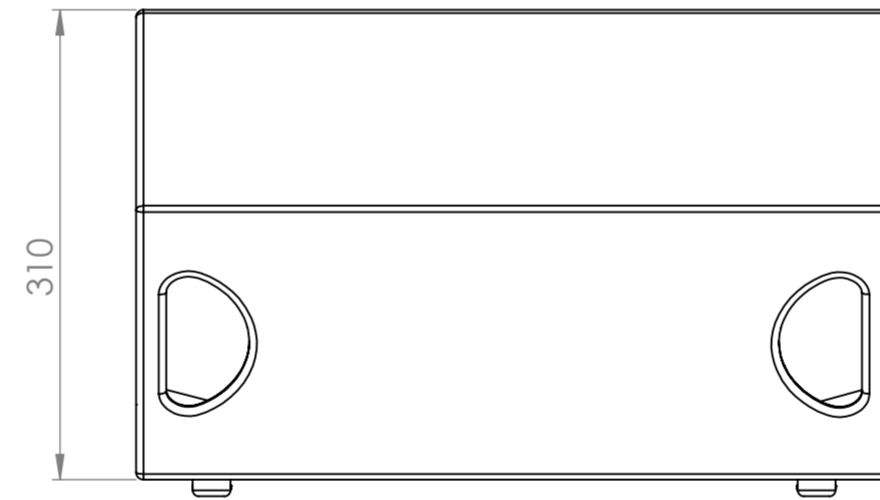

Rear View

Model	HCS-112CM
TYP	12" Source Point Coaxial Monitor
Frequency Range	49Hz -20kHz
Power Handling	500W AES / 1000W program / 2000W peak
Sensitivity	100 dB 1W/1Meter
Impedance	8 Ohm
Dimensions	310x500x399 mm
Weight	15,0 Kg

WENN NICHT ANDERS DEFINIERT, BEMASSUNGEN SIND IN MILLIMETER OBERFLÄCHENBESCHAFFENHEIT: TOLERANZEN: LINEAR: WINKEL:				OBERFLÄCHENGÜTE:		ENTGRATEN UND SCHARFE KANTEN BRECHEN		ZEICHNUNG NICHT SKALIEREN		ÄNDERUNG	
GEZEICHNET				NAME		SIGNATUR		DATUM		BENENNUNG:	
GEPÜFT											
GENEHMIGT											
PRODUKTION											
QUALITÄT								WERKSTOFF:		ZEICHNUNGSNR.	
										HCS-112CM--CAD-REV01-0718 A2	
								GEWICHT:		MASSTAB:1:5	
										BLATT 1 VON 1	